

17021
DIE NUMBER

EXPOSED

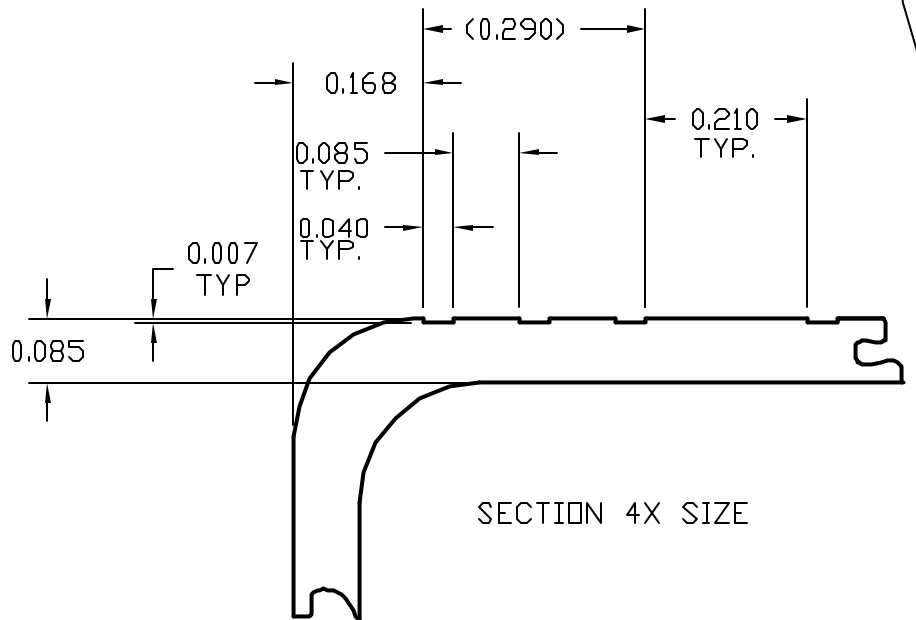
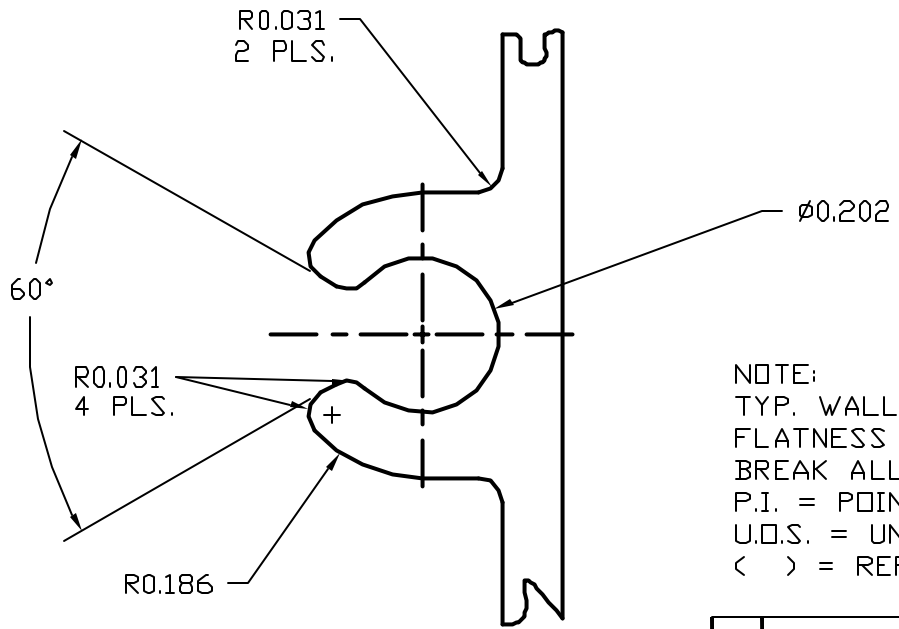
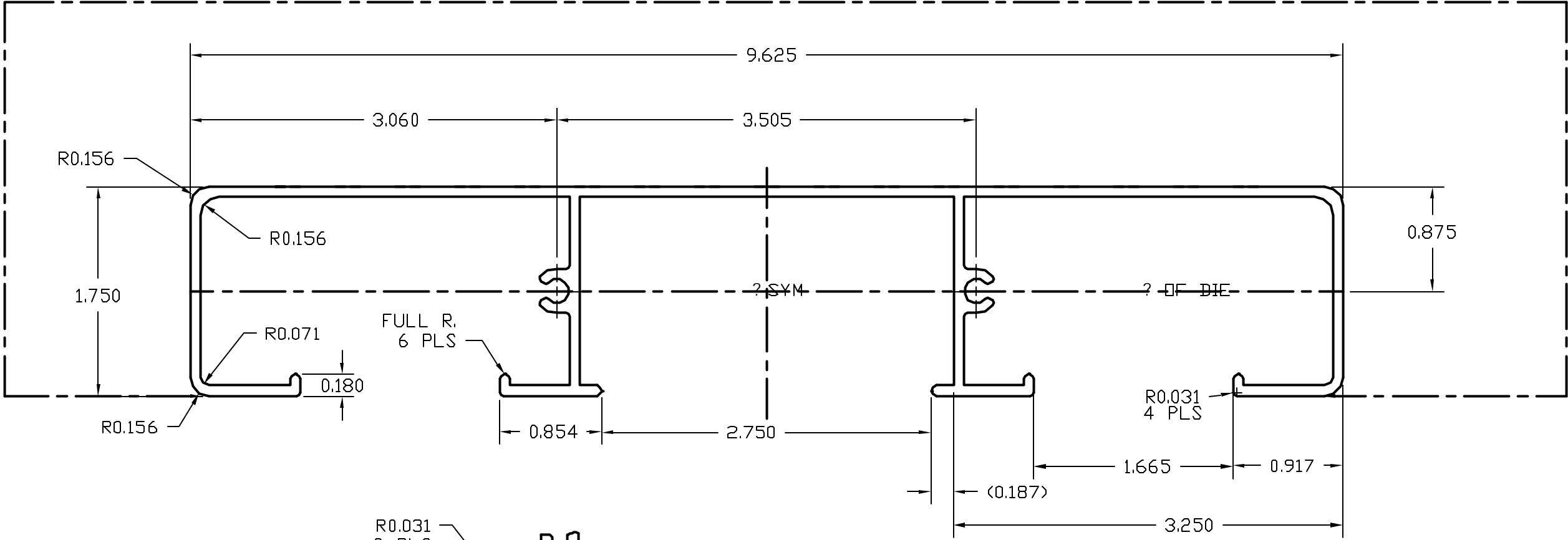

NOTE:
TYP. WALL THICKNESS .085
FLATNESS TOLERANCE .008/IN. OF WIDTH (.077 TOTAL)
BREAK ALL SHARP CORNERS 0.015 R.
P.I. = POINT OF INTERSECTION
U.O.S. = UNLESS OTHERWISE SPECIFIED
() = REFERENCE DIMENSION

EXTRUDED ALUMINUM CORPORATION IS NOT IN ANY WAY RESPONSIBLE FOR THE DESIGN OR APPLICATION OF THIS PART. THE ALUMINUM ASSOCIATION STANDARD COMMERCIAL TOLERANCES APPLY UNLESS OTHERWISE SHOWN.

REVISIONS	DRAWING SCALE	FULL	RATIO	45:1
REV. TOOLING 3-16-93 NJS	EST. AREA	1.755	DIE SIZE	14X6
REVISED 6-20-77	EST. WEIGHT	2.106	NO. HOLES	1
PART NO. WAS 445441 6-15-77	OUTER PERIM.	41.742	BACKER NO.	17021
10.5 CONT. RR=49:1	INNER PERIM.		FEEDER NO.	
	CIRCUM. C.	9.75	VENDOR	THUMB



Extruded Aluminum CORPORATION

7200 Industrial Dr.
Belding, MI. 48809

PHONE (616) 794-0300
FAX (616) 794-0879

DRN. BY PD	DATE 05/25/07	REVISION LEVEL
CUSTOMER QUALITY INDUSTRIES		
PART NO. 200675		
PART NAME ALUMINUM EXTRUSION		
BOLSTER	SUB-BOLSTER	SPACER
5	862	605
DIE NUMBER		17021
DRAWING/QUOTE NUMBER		