

NOTE:

DIE #3 = 14 x 6 FOR PRESS 5
DIE #4 = 15.930 x 6 FOR PRESS 1

EXTRUDED ALUMINUM CORPORATION IS NOT IN ANY WAY RESPONSIBLE FOR THE DESIGN OR APPLICATION OF THIS PART.

OUR STANDARD COMMERCIAL TOLERANCES APPLY UNLESS OTHERWISE SHOWN.

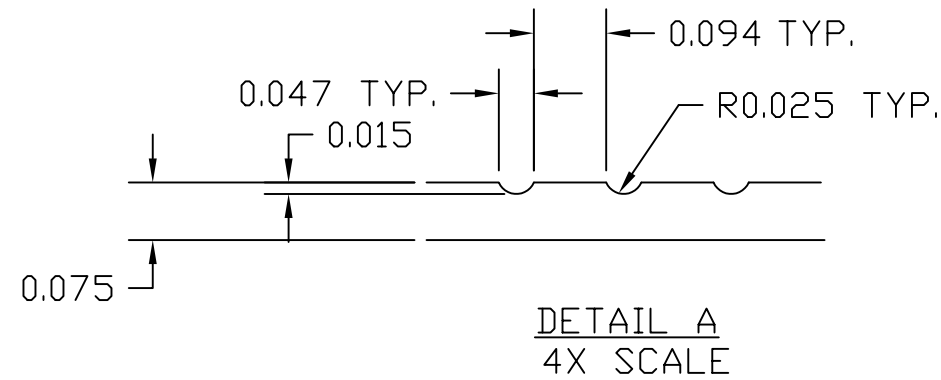

REVISIONS

EST. AREA	1.554	DIE SIZE	SEE NOTE
EST. WEIGHT	1.865	NO. HOLES	1
EST. PER.	40.410	BACKER NO.	20811
FACTOR	22	BACKER SIZE	
CLASSIFICATION	SOLID	FEEDER NO.	20811
CIRCUM. C.	9.736	FEEDER SIZE	
MATERIAL	6063-T6	TOLS.	STANDARD

NUMBER OF DIES IN STOCK _____			
		7200 Industrial Dr. Belding, MI. 48809	
Extruded Aluminum CORPORATION		PHONE (616) 794-0300 FAX (616) 794-0879	
DRN. BY DJS	CKD. BY	DATE 01/23/97	
CUSTOMER JACK K. ELROD			
PART NO. 13379-C		REV. A	
PART NAME STADIUM SCALE FULL			
5	862 (5.93)	BOLSTER	20811
1	1031 (NEW)	605 (4.0)	DIE NUMBER